

400S HC3

TELESCOPIC HI-CAPACITY BOOM LIFT

BOOM LIFT



HC3

KEY SPECS

Platform Height
40-ft / 12.19-m

Drive Speed
4.25 mph / 6.8 km/h

Horizontal Outreach
33-ft 7-in / 10.23-m

Platform Capacity
Restricted: 750/1,000-lb / 340/454-kg
Unrestricted: 660-lb / 300-kg

KEY FEATURES

- Utilizes three working zones for enhanced capacity; up to three workers and tools can fit onto the platform.
- Utilizes an upgraded light panel that is more visible in the sun, and a chassis tilt alarm that alerts the operator when the machine is on a slope that exceeds 5 Degrees.
- Delivers a zero calibration automatic load sensing system that eliminates the need to use external weights to calibrate the machine.
- Complies with A92.20 ANSI regulations, achieving the highest standards.

ACCESSORIES & OPTIONS

- 1/2-in Air Line to Platform
- AC Generator, 2500W or 4000W
- Accessory Packages
 - SkyPower® Package
 - SkyGlazier® Package
 - SkyWelder® Package
- Arctic Package¹
- Bolt On Fall Arrest System
- Cold Weather Package²
- Hostile Environment Package³
- Light Package
- Platform Mesh to Mid or Top Rail
- Aluminum or Plastic Platforms
 - Drop Bar, 30 x 36-in, 30 x 60-in, 36 x 72-in, 36 x 96-in
 - Drop Bar, 30 x 36-in, 30 x 60-in, 36 x 72-in, 36 x 96-in
 - Fall Arrest, Rear Entry, 36 x 72-in, 36 x 96-in
 - Inward Self-Closing Swing Gate, 30 x 60-in, 36 x 72-in, 36 x 96-in
- Tri-Entry, Drop Bar or Swing Gate, 36 x 72-in, 36 x 96-in
- SkySense® Enhanced Detection System
- Soft Touch System
- Storage Tray - Center or Corner

STANDARD SPECIFICATIONS

Performance

Platform Height	40-ft / 12.19-m
Horizontal Outreach	33-ft 7-in / 10.23-m
Swing	360 Degrees Continuous
Platform Capacity (Restricted)	750/1,000-lb / 340/454-kg
Platform Capacity (Unrestricted)	660-lb / 300-kg
Platform Rotator	180 Degrees Hydraulic
Weight*	15,040-lb / 6,882-kg
Max. Ground Bearing Pressure	65 psi / 4.57 kg/cm ²
Drive Speed	4.25 mph / 6.8 km/h
Gradeability	45%
Tilt Cut Out	5 Degrees
Turning Radius (Inside/Outside)	6-ft 5-in (2.0-m) / 15-ft 8-in (4.8-m)

Engine

Diesel Fuel – Deutz D2.9L4 Tier 4 Final	49 hp / 36.4 kW
Fuel Tank Capacity	22 gal / 83.3 L

Tires

Standard	Foam Filled, 14x17.5
Optional	Foam Filled Non-Marking, 12x16.5
	Foam Filled Non-Marking, 14x17.5
	Foam Filled, 14x17.5
	Foam Filled, 33x12 D610
	Foam Filled, Turf & Sand, 33/16LLx16.1

Hydraulic System

Hydraulic Reservoir	36 gal / 136.27 L
Auxiliary Power	12V DC

STANDARD FEATURES

- 5 Degree Tilt Alarm / Indicator Light
- 12V-DC Auxiliary Power
- 110V-AC Receptacle in the Platform
- 180 Degree Hydraulic Platform Rotator
- ClearSky Smart Fleet™ Hardware (CS550)
- Control ADE® System
- Four-Wheel Hydrostatic Drive
- Glow Plugs (Diesel Engines)
- Horn
- Hourmeter
- Improved Multi-Function Controls
- Interactive Display at Ground Controls
- LED Motion / Amber Beacon (CS550)
- Lifting / Tie Down Lugs
- Motion Alarm
- Oscillating Axle
- Platform Console Machine Status Light Panel**
- Proportional Controls
- Reduced Time to Full Height
- SkyGuard SkyLine™
- Swing-Out Engine Tray

*Certain Options or Country Standards Increase Weight.

**Provides Indicator Lights at Platform Control Console for System Distress, Low Fuel, Degree Tilt Light and Foot Switch Status.

- Includes arctic hydraulic hoses (drive and steer only) and main boom cable, arctic hydraulic oil, extreme cold engine oil, fuel conditioner, engine block heater, battery blanket, glow plugs, hydraulic tank heater, and oversized footswitch.
- Includes battery blanket, hydraulic tank heater, block heater.
- Includes console cover, boom wipers and cylinder bellows.

Note: Some options may increase lead time, and some option combinations may not be available. Additional accessories and options available via JLG Aftermarket.

400S HC3

BOOM LIFT

TELESCOPIC HI-CAPACITY BOOM LIFT



DIMENSIONS

All dimensions are approximate

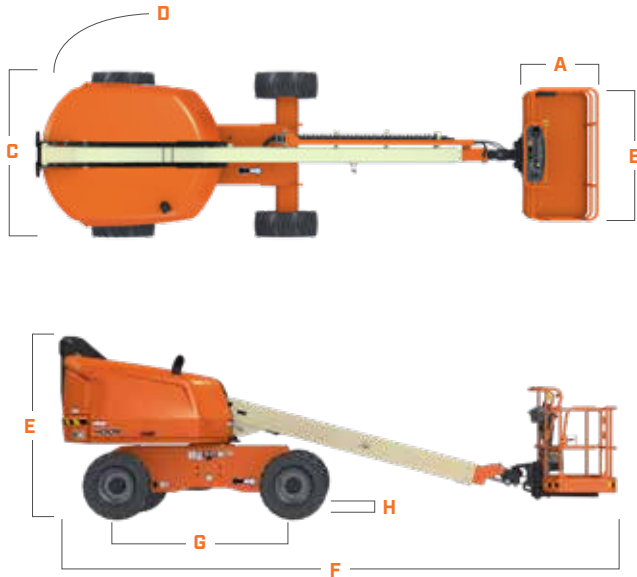

A.	Platform Width	36-in / 0.91-m
B.	Platform Length	96-in / 2.44-m
C.	Machine Width	7-ft 6.8-in / 2.31-m
D.	Tailswing	2-ft 10-in / 86-cm
E.	Machine Height	8-ft 14-in / 2.47-m
F.	Machine Length	24-ft 11-in / 7.6-m
G.	Wheelbase	7-ft 9.5-in / 2.37-m
H.	Ground Clearance	12.1-in / 31-cm

REACH DIAGRAM

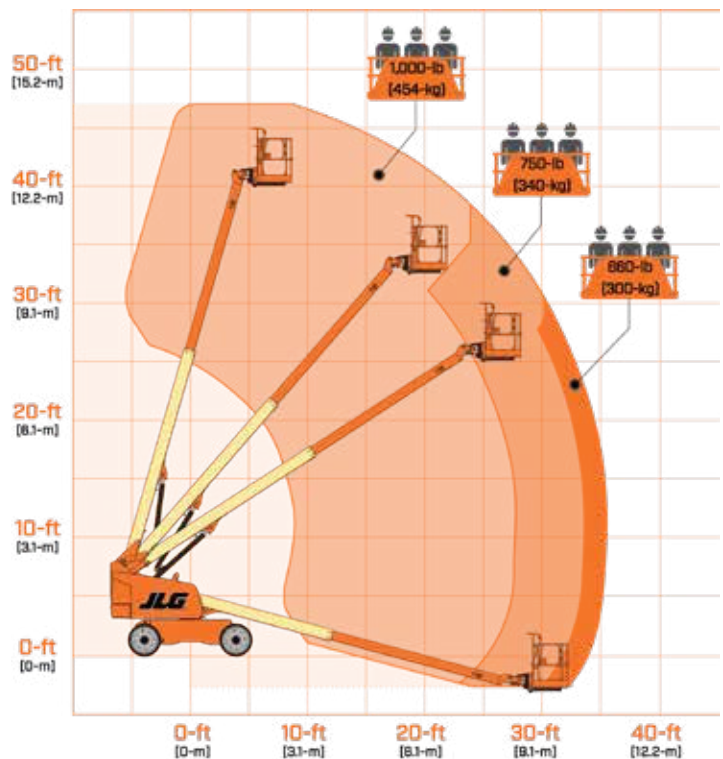

We provide coverage for one (1) full year, and cover all specified major structural components for five (5) years. Due to continuous product improvements, we reserve the right to make specification and/or equipment changes without prior notification. This machine meets or exceeds applicable ANSI and CSA requirements based on machine configuration as originally manufactured for intended applications. Please reference the serial number plate on the machine for additional information.



JLG INDUSTRIES, INC.
Toll-free US 877-JLG-LIFT
JLG.com

An Oshkosh Corporation Company