

E18MSP

DRIVEABLE STOCK PICKER

STOCK PICKER



KEY SPECS

Platform Height
18-ft / 5.5-m

Platform Capacity
400-lb / 181-kg

Turning Radius
Zero

Stowed Drive Speed
2.5 mph / 4 km/h

KEY FEATURES

- Designed with the operator in mind, featuring familiar controls, Point and Go steering, ergonomic joystick and ease of entry/exit from platform.
- Lightweight and compact footprint is ideal for sensitive flooring and accessing tight spaces with high transportability.
- Increase productivity with longer running batteries and optional platforms, trays and accessories.
- Quick access to key, known scissor components and durable mast protection offers efficient serviceability while the multi-display indicator provides real-time fault code and maintenance information to maximize uptime.

ACCESSORIES & OPTIONS

- Anti-Vandalism Package
- ClearSky™
- Front and Side Bumpers
- CleanGuard™
- Crane Hook
- USB Charger & Phone Cradle

STANDARD SPECIFICATIONS

Performance	Indoor ONLY
Platform Height (Elevated)	18-ft / 5.5-m
Working Height	24-ft / 7.5-m
Platform Capacity	400-lb / 181-kg
Work Tray Capacity	100-lb / 45-kg
Number of Occupants	1
Lift / Lower Time ¹	23/23 seconds
Maximum Drive Height	Fully Elevated
Weight*	1,950-lb / 885-kg
Ground Bearing Pressure	TBD
Drive Speed (Elevated)	0.5 mph / .8 km/h
Drive Speed (Lowered)	2.5 mph / 4 km/h
Gradeability	30%
Turning Radius (Inside)	Zero
Turning Radius (Outside)	48-in / 1.2-m

Power Source

Battery	Four 6V - 220 AH (2X More Duty Cycles Over Competition)
Charger	27 amp
Drive	4 Brush Direct Electric Drive (Planetary Gear)

Lift & Steer Systems

Lift	Hydraulic
Steer	Point & Go

Tires

Front / Rear	8-in Casters / 10 x 3-in Non-Marking
--------------	--------------------------------------

Brakes

Electric	
----------	--

STANDARD FEATURES

- 27 amp Multi-Function Universal Charger
- 28 x 29.5-in Side Entry Work Tray Platform with Saloon Doors and Gate Alarm
- AC Receptacle in Platform
- Active Pothole Protection System
- All Motion Alarm
- Analyzer Port for Diagnostics
- Battery Condition Indicator
- DC Electric Drive
- Dual Amber Beacon
- Dynamic Braking
- Electric Brake Release
- Floor Mat
- Fork Lift Pockets
- Greaseless Kingpin Joints
- Horn
- Hourmeter
- Lanyard Attach Points
- Lifting and Tie Down Points
- Load Sensing System
- Manual Descent
- Mast Maintenance Prop
- Movable, Removable Platform Control with 6-ft Coiled Cable
- Multi-Display Indicator
- Proportional Controls
- Tilt Alarm and Light
- Telematics Ready

QUICK CHANGE PLATFORM OPTIONS

- Fold-Down Work Tray Platform
 - 28 x 29.5-in
 - Platform Capacity, 400-lb
 - Tray Capacity, 100-lb
- Platform Entry Styles
 - Side Entry Drop Bar
 - Aluminum Tray with Side Entry Saloon Doors

*Certain options or country standards increase weight.

1. Average range, refer to Operations Manual.

2. Tray capacity of 100-lb / 45-kg

3. Extension platform capacity of 250-lb.

E18MSP

DRIVEABLE STOCK PICKER

STOCK PICKER



DIMENSIONS

All dimensions are approximate

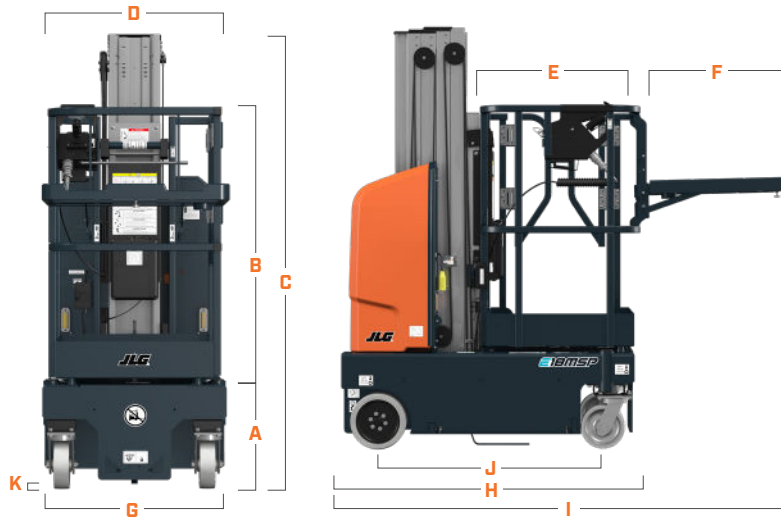

A. Platform Entry Height	18.5-in / 47-cm
B. Platform Rail Height	43.8-in / 1.11-m
C. Machine Height	78-in / 1.98-m
D. Platform Width	28-in / 71-cm
E. Platform Length	29.5-in / 75-cm
F. Platform Tray	25-in / 63-cm
G. Machine Width	30-in / 76-cm
H. Machine Length - Retracted Tray	57.6-in / 1.46-m
I. Machine Length - Extended Tray	81-in / 2.06-m
J. Wheelbase	41.4-in / 1.05-m
K. Ground Clearance	2.5-in / 6.35-cm



We provide coverage for one (1) full year, and cover all specified major structural components for five (5) years. Due to continuous product improvements, we reserve the right to make specification and/or equipment changes without prior notification. This machine meets or exceeds applicable ANSI and CSA requirements based on machine configuration as originally manufactured for intended applications. Please reference the serial number plate on the machine for additional information.



JLG INDUSTRIES, INC.
Toll-free US 877-JLG-LIFT
JLG.com

An Oshkosh Corporation Company